

Printable, Plastic RFID Tags

Printed Electronics 2004

December 7, 2004

Klaus Dimmler
President & CEO
Klaus@OrganicID.com

OrganicID, Inc.
422 East Vermijo
Suite 409
Colorado Springs, CO 80903
719-219-6522
Info@OrganicID.com
www.OrganicID.com

Company Overview

- OrganicID was founded in December 2003
- **Mission:** To develop low-cost organic electronic process technology to produce printable electronic RFID tags for bar code replacement
- Developing technology with and co-founded by Dr. Ananth Dodabalapur, who is formally of Bell Labs' well known organic electronics group
- Main emphasis is not on materials, but rather on device designs and manufacturing process

Agenda

RFID Market

What do the device targets need to be?

What can be accomplished?

Building an organic RFID tag

RFID Market Need

- Typical prices of the cheapest tags in the current market are **\$0.20**
- Estimates predict that silicon may never get to \$0.05
- Prices of **\$0.01** or less will be needed for *Item Level Tracking*
- Estimates using fully printable methods will yield **\$0.01**

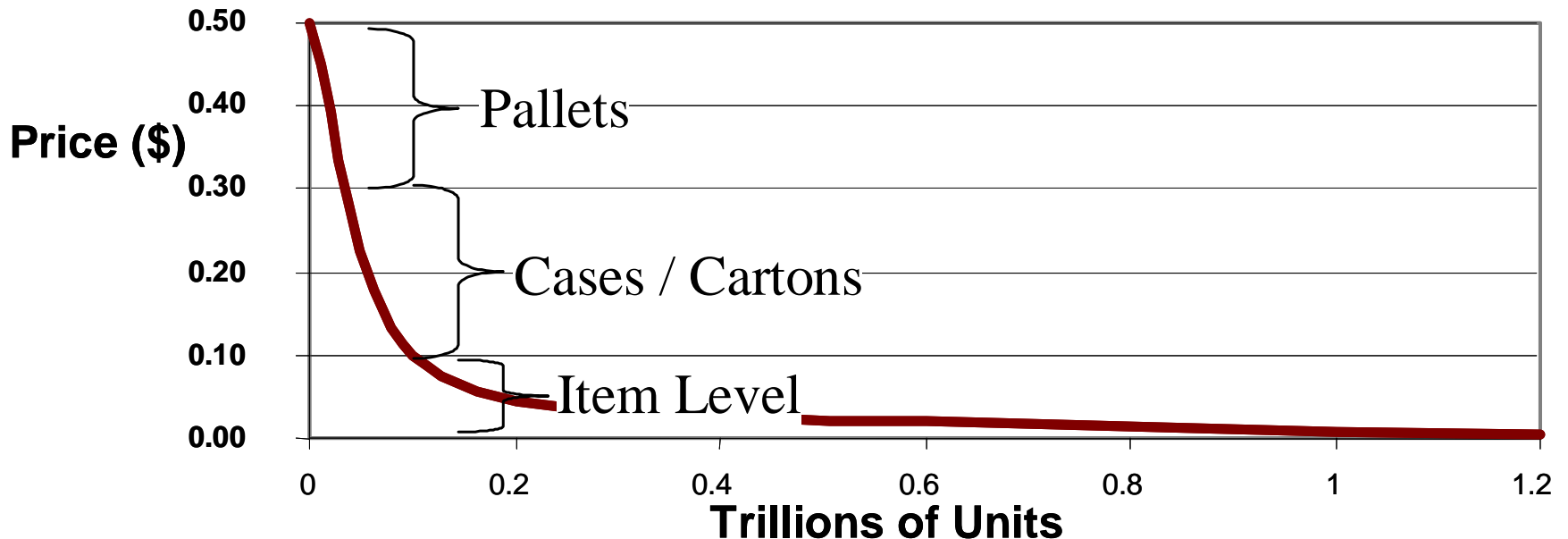

Frequency Comparison

	<u>Low Frequency</u>	<u>High Frequency</u>	<u>Ultra-High Frequency</u>	<u>Microwave</u>
Frequency	125kHz	13.56MHz	868-915MHz	2.45GHz
Max Range	10 feet	10 feet	40 feet	90 feet
Tech Maturity	High	High	Medium	Low
Applications	Access control Vehicle immobilizers Animal Tracking POS applications	Item level tracking Smart Cards/Tickets Lead Retrieval Industrial/Scientific Medical	Pallet tracking Toll collection Baggage handling	Asset tracking Toll collection
Attributes	Available Globally and less impacted by metal Large antenna Expensive	Available Globally Wider acceptance due to smart card adoption Better form factor Better penetration Lower Cost Lower Power	Long read range Blocked by tissue Larger Antenna Europe uses 13.56MHz US uses 915MHz Japan uses 2.4GHz	Available globally, very focused signal Blocked by tissue
Anti-collision	About 50/sec	About 50/sec	200-1000/sec	200-1000/sec

Sampling of RFID Pilots

Industry	Company	Frequency	Price/Tag
Pallets/Cases	Gillette	915MHz	\$0.25
	International Paper	915MHz	\$0.30
	Raxel	915MHz	\$1.00
	CHEP	915MHz	\$2.00
	Wal-Mart	915MHz	\$0.78
Item Level	Benetton	13.56MHz	\$0.50
	Metro AG	13.56MHz	\$1.00
	Prada	13.56MHz	\$3.00
	The Gap	13.56MHz	\$1.00
	Revlon	13.56MHz	\$0.35
	Mark and Spencers	13.56MHz	\$1.00
	Wal-Mart, Broken Arrow	13.56MHz	\$0.20

Organic Transistors

The Pros

- Compatibility with flexible plastic substances
- Lower temperature manufacturing (60-120°C)
- Lower-cost printable deposition processes

The Cons

- Lower mobility
- Low switching speeds
- Manufacturing not developed



RFID Tag Targeted Performance

- Due to transistor structure, circuit design, materials chosen, and manufacturing process, an OrganicID Tag will meet industry specifications

Specification	Min	Typ	Max	Units
RF Carrier Frequency	12.5	13.56	14.6	MHz
Minimum Reader Antenna Voltage during Tag Transmission	10			mV
Processor Clock Frequency		106		kHz
Memory Size	192			bits
EPC Global Compatibility				
ISO 15693 Compatibility				
Operating Temperature	-40		85	°C

Tag Architecture

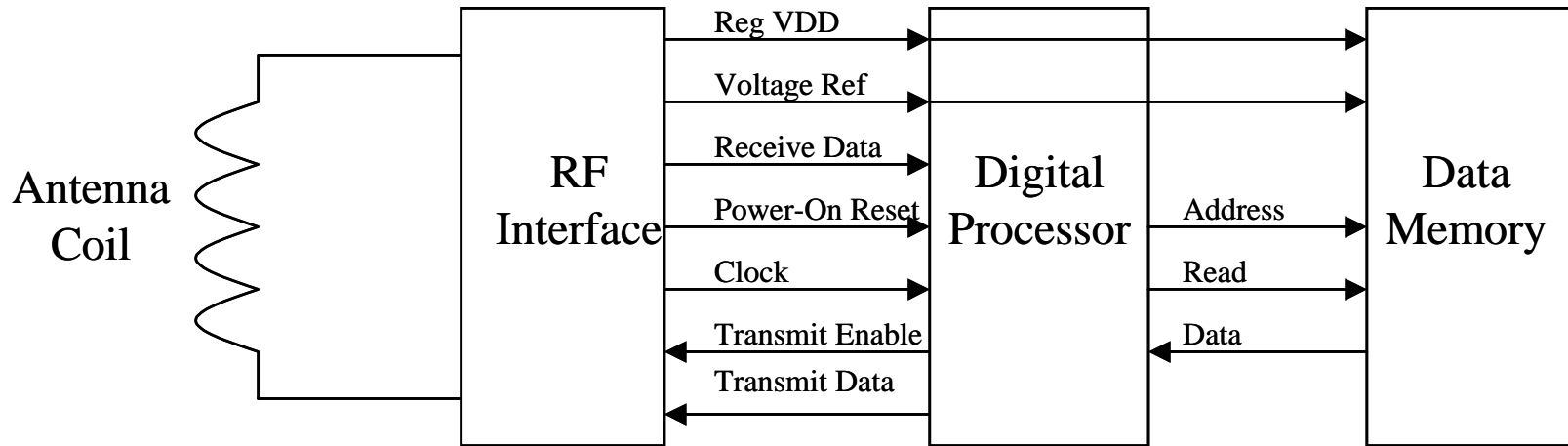

- **RF Interface provides all Analog/RF functionality**
Regulates power supply; modulation/demodulation; clock generation; reset signals
- **Digital Processor handles control functions and data processing tasks**
operating modes; data communications protocol; anti-collision protocol
- **Data Memory stores/retrieves relevant Tag data such as ID number**

Performance Challenge

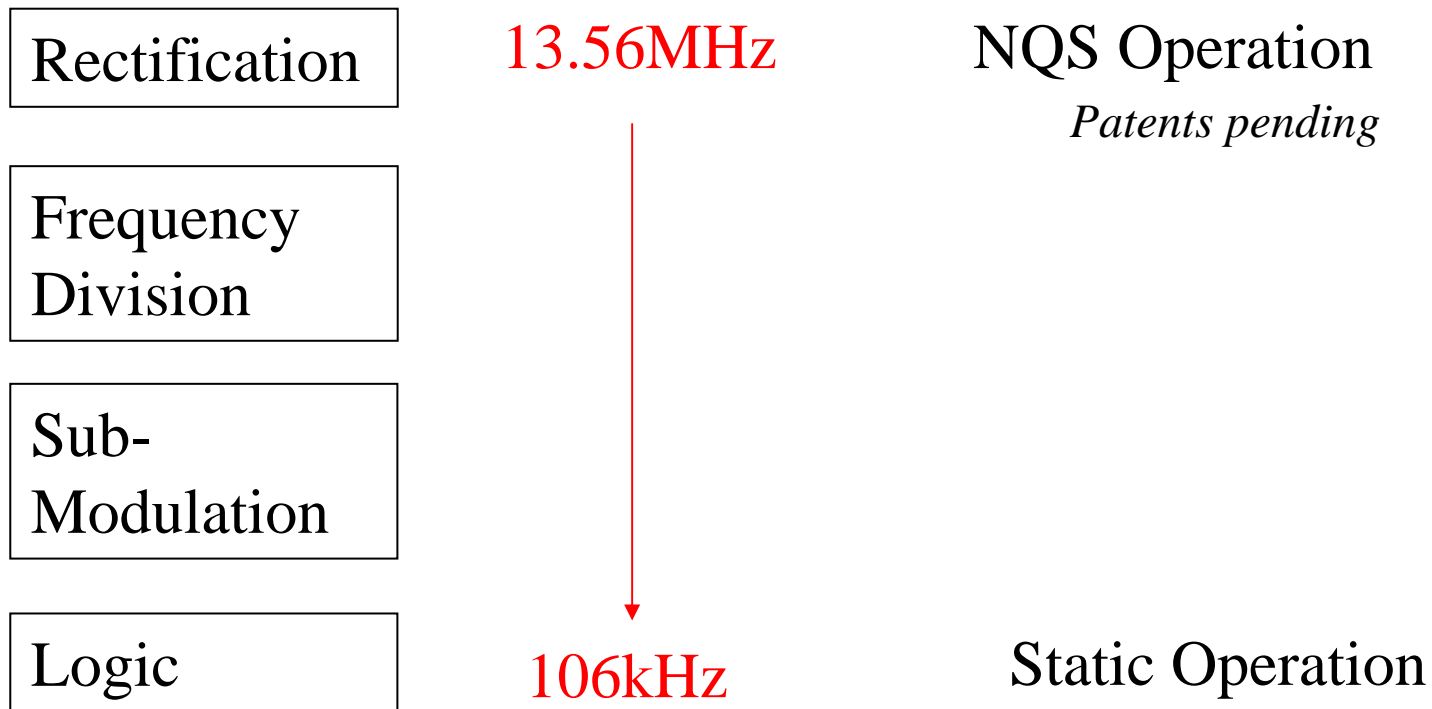

Process Features

CMOS- integrated p-type and n-type material

10x less power for the same frequency of operation

Tag Power specifications can be met by p-type design

Programmable memory

10-14v programming voltage

Design Rules

Typical resolution: 25 μ m - 50 μ m

Alignment Tolerance: 25 μ m

Minimum space in source/drain metal: 3 μ m

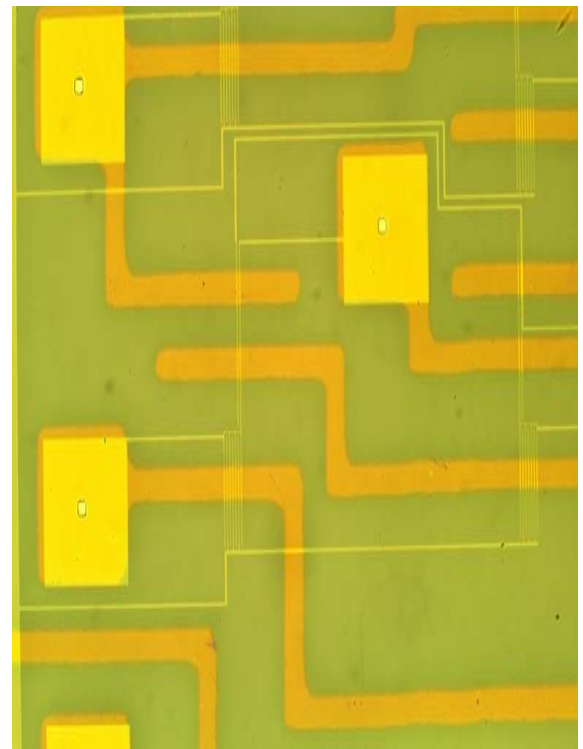

Target Transistor Characteristics

3 μ m channel length

1v-2v threshold

Power Supply: 10v

on/off ratio: 10^3

mobility 0.1 to 0.3 cm²/Vs

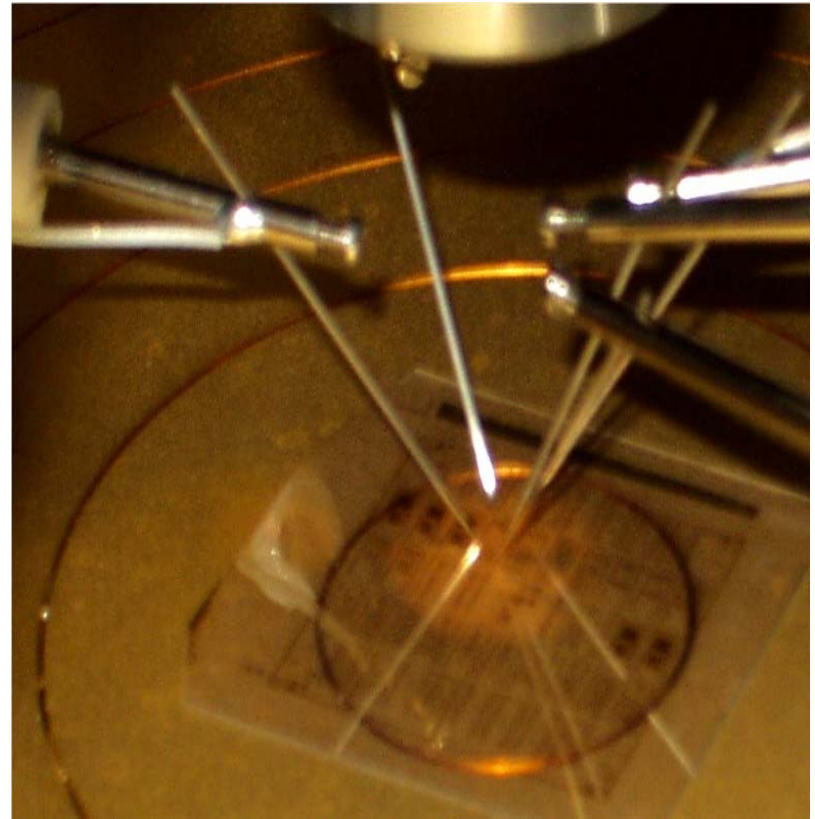

Development Strategy

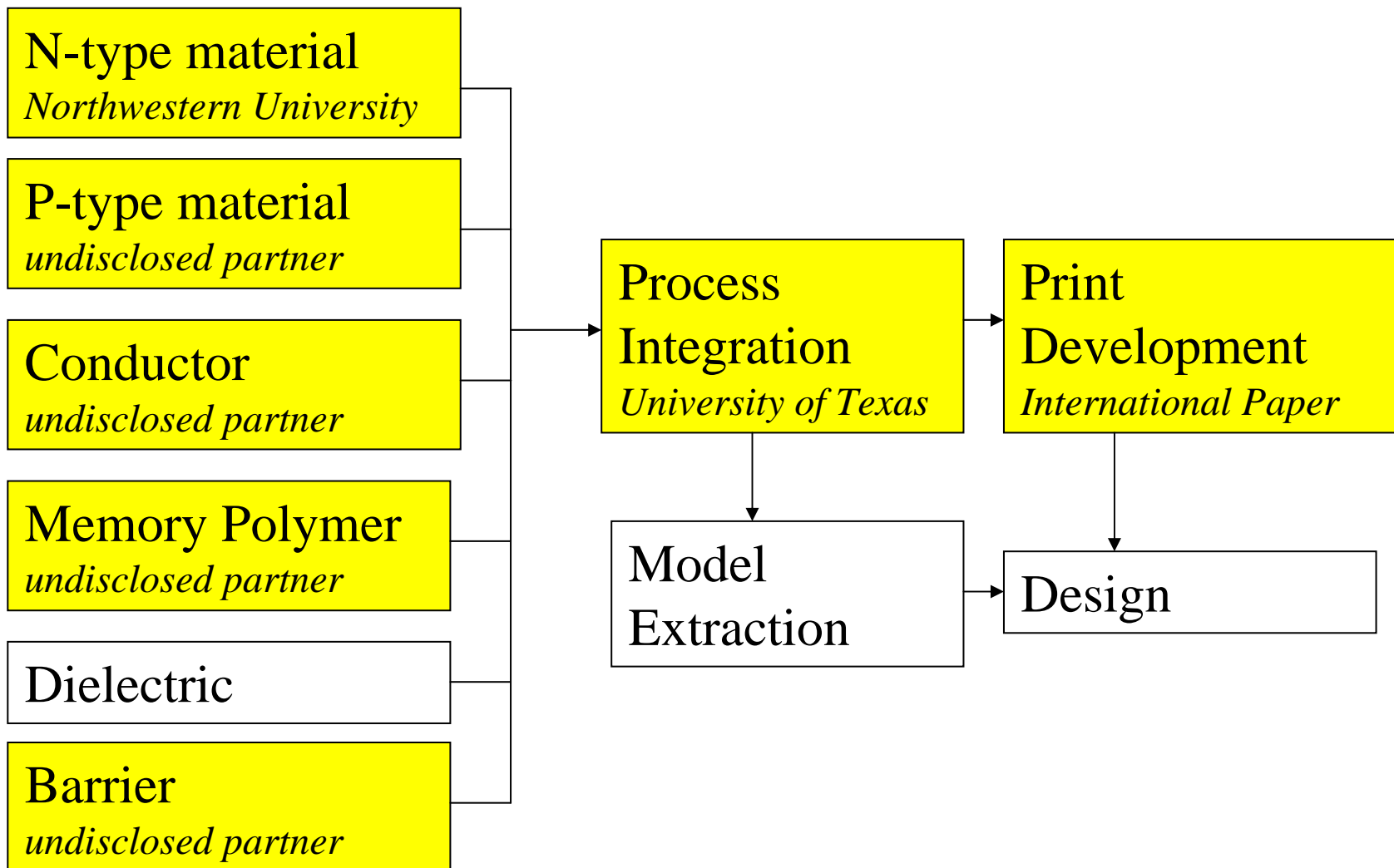

Process Integration Development

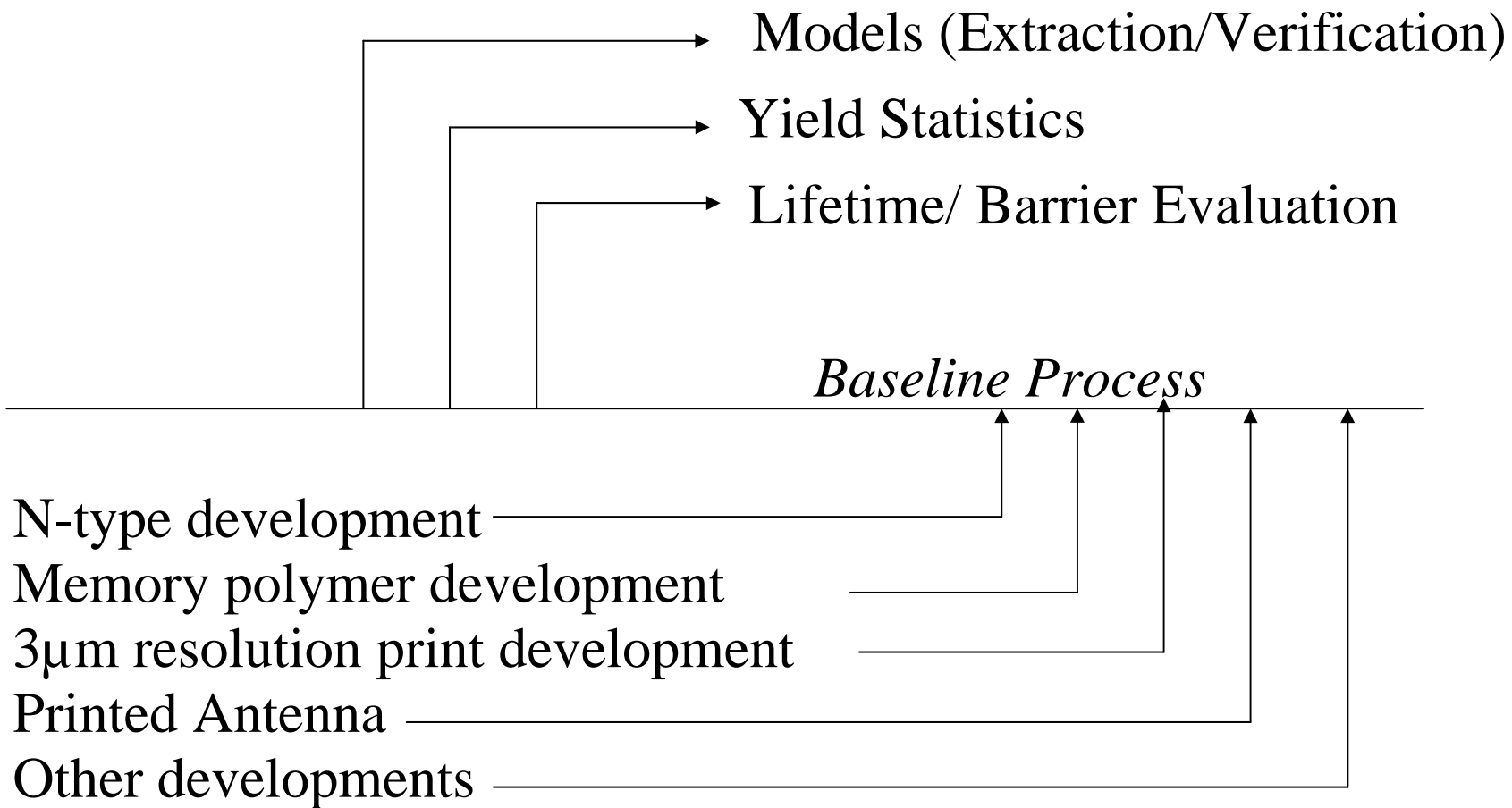

Current Development Status

Test Chip running through baseline process

Approaching transistors targets

RFID sub-circuits- rectifier functionality up to 17MHz

Computer Circuit Models

Initial version of model available (Cadence/Verilog A)

Secondary effects now being incorporated

Printing

Evaluation stage

Results- p-type Transistors

Substrate: PEN

Mobility with printable semiconductor: $0.2 \text{ cm}^2/\text{Vs}$

Mobility with sublimated pentacene: $2 \text{ cm}^2/\text{Vs}$

$V_t = 2\text{v}$; $V_{\text{operating}} = 10\text{v}$

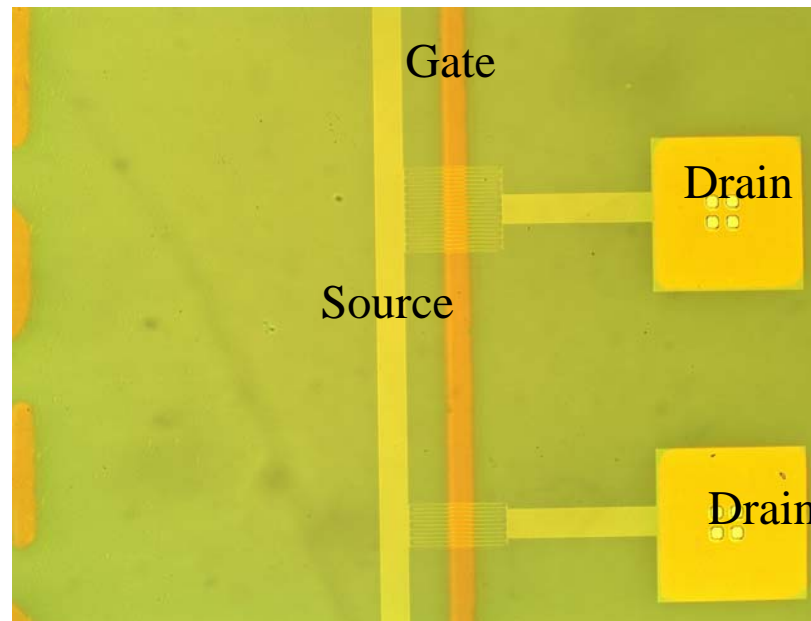
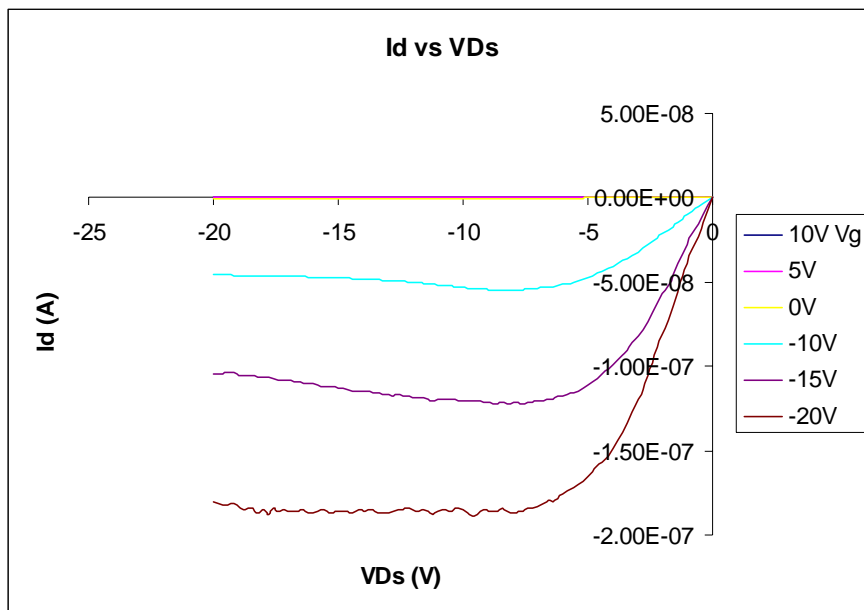

Individual Devices

Results- n-type Transistors

Substrate: PEN

Mobility with n-type semiconductor: $0.2 \text{ cm}^2/\text{Vs}$

$V_t = 5\text{v}$; $V_{\text{operating}} = 15\text{v}$

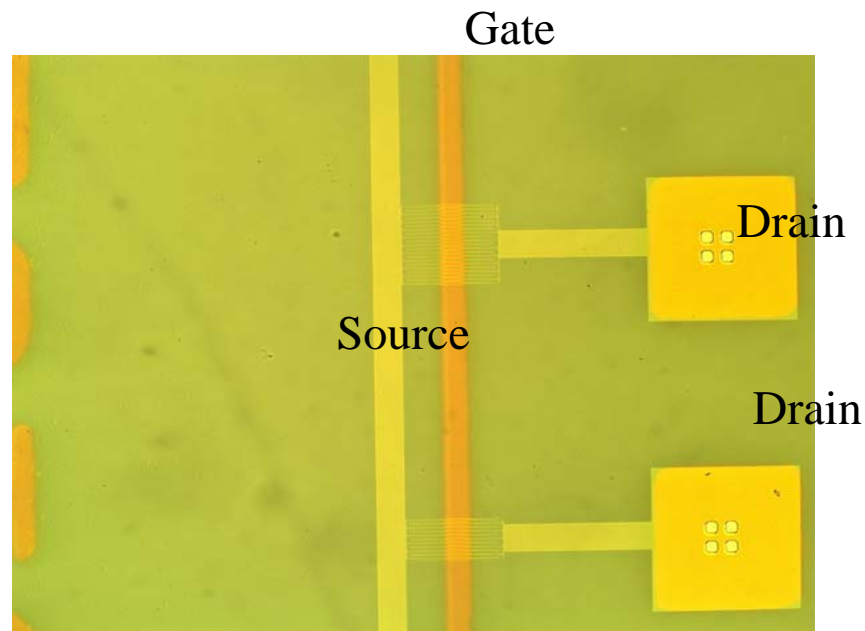
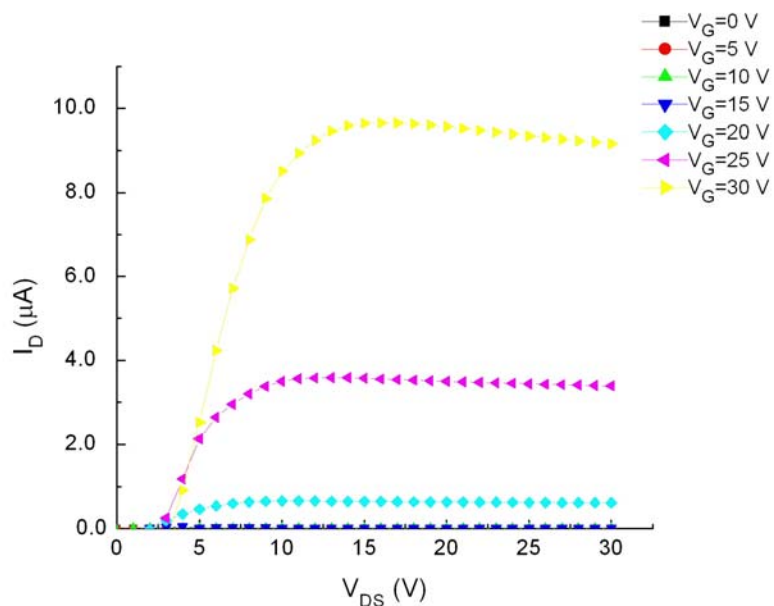

Individual Devices

Results- Circuits

Rectifier: functionality at 17Mhz demonstrated

Logic: functionality achieved

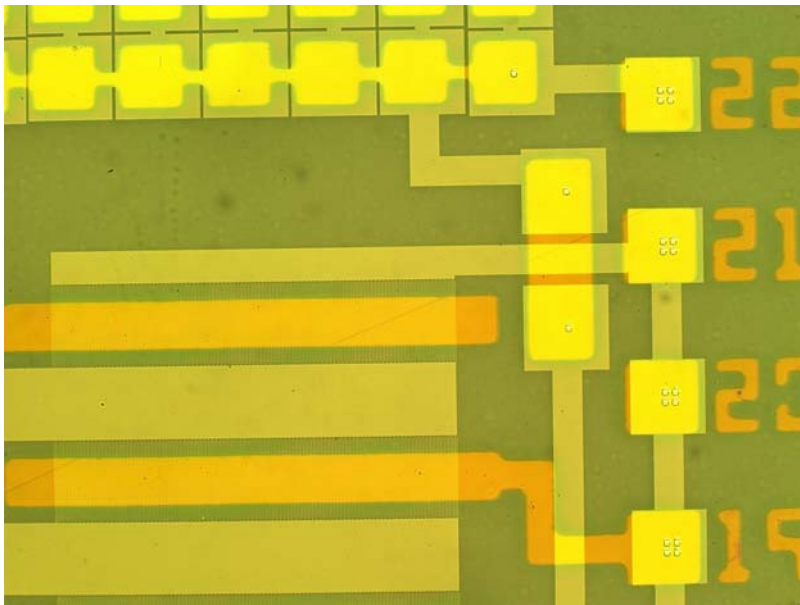

Portion of Rectifier

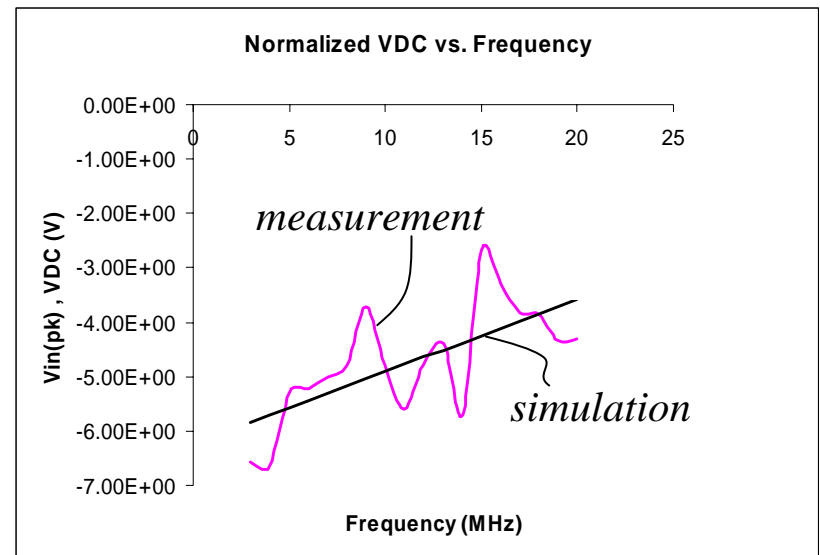

Frequency Response of Rectifier

Results- Non-Volatile Memory

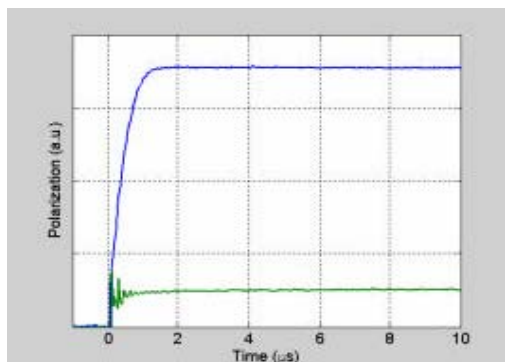

Large signal strength

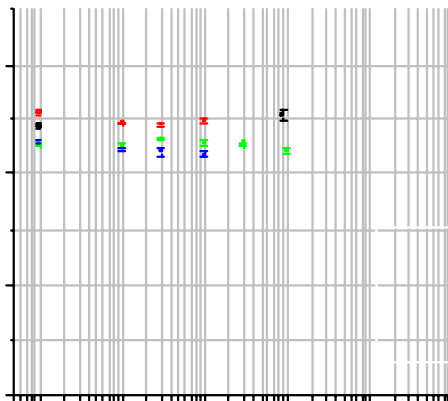

Good Retention

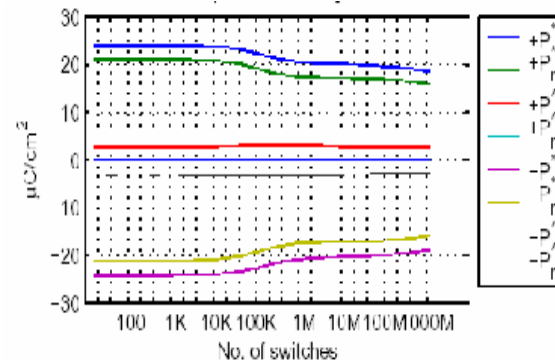

Good Endurance

Data from undisclosed development partner

Patterning by Print

- OrganicID and International Paper are working together to develop the high volume printing process.
- Gravure is the primary focus for circuit layers. Screen printing is primary focus for antenna. Flexography and ink jet technologies are also being considered.
- Design rules mainly target 20-50 μ m resolutions.
- Source/Drain metal patterning at 3 μ m resolution being jointly developed with an undisclosed partner.

Conclusion

- OrganicID is focused on the process integration and product development. Many materials and partners have been identified.
- Existing organic transistor performance is sufficient to meet 13.56MHz performance. Functionality demonstrated in OrganicID organic process flow.
- OrganicID is actively pursuing relationships with others in the industry

Contact Information

For further information please contact OrganicID directly

Klaus Dimmler

President & CEO

Klaus@OrganicID.com

Jon Barad

VP of Business Development

Jon@OrganicID.com

OrganicID, Inc.

422 East Vermijo

Suite 409

Colorado Springs, CO 80903

719-219-6522

www.OrganicID.com